



ISA BUS Isolated Data Acquisition Board Selection Guide

Model No.	ISO-AD32H/L	ISO-813	ISO-LDH/L	ISO-DA8	ISO-DA16	
Bus	AT	AT	AT	AT	AT	
Analog Input Channels	32 S.E. 16 DIF.	32 S.E.	1	-	-	
Strain Gauge Input	-	-	1	-	-	
Analog Input Resolution	12 bits	12 bits	12 bits	-	-	
Analog Input Range (V)	Bipolar Low gain	$\pm 10, \pm 5, \pm 2.5$ ± 1.25	$\pm 5, \pm 2.5, \pm 1.25,$ $\pm 0.625, \pm 0.3125$	-	-	
	Bipolar High Gain	$\pm 10, \pm 5, \pm 1$ $\pm 0.5, \pm 0.1,$ ± 0.05	-	-	-	
	Unipolar Low gain	0~10, 0~5, 0~2.5	0~10, 0~5, 0~2.5, 0~1.25, 0~0.625	0~10, 0~5, 0~2.5, 0~1.25	-	-
	Unipolar High gain	0~10, 0~1, 0~0.1	-	0~10, 0~1, 0~0.1, 0.01	-	-
Analog Output	Channels	-	-	8	16	
	Resolution	-	-	14 bits	14 bits	
	Range (V)	-	-	$\pm 10, \pm 5$ 0~5, 0~10	$\pm 10, \pm 5$ 0~5, 0~10	
	Range (mA)	-	-	0~20, 4~20	0~20, 4~20	
On-Board FIFO	1K bytes	-	1K bytes	-	-	
Speed	200KHz	10KHz	16KHz	-	-	
Digital I/O Channels	-	-	8 isolated input 7 isolated O.C. output 8 TTL output	16 TTL Input 16 TTL Output	16 TTL Input 16 TTL Output	
Channel Scan	Yes	-	-	-	-	
Page	45 - 46	51	49 - 50	47 - 48	47 - 48	

Isolated Digital I/O, Counter, Relay Output Board Selection Guide

Model No.	ISO-P32C32	ISO-C64	ISO-P64	ISO-730	P8R8DIO	P16R16DIO
Bus	AT	AT	AT	AT	AT	AT
Isolated Input Channels	32	-	64	16	-	16
Input Range	5-24V	-	5-24V	5-24V	-	5-24V
Isolated Output Channels	32	64	-	16	-	16
Driving Capacity	Open-collector 100 mA sink	Open-collector 100 mA sink	-	Open-collector 100 mA sink 200 mA max.	-	125V/0.3A relay
Non-isolated D I/O	-	-	-	16 DI 16 DO	-	-
Other Function	Built-in DC/DC	On board Fuse, LED	Built-in DC/DC	Built-in DC/DC	4 Form C relay 4 Form A relay	8 Form C relay 8 Form A relay
Connectors	1 x 40-pin 1 x DB-37	1 x 40-pin 1 x DB-37	1 x 40-pin 1 x DB-37	1 x DB-37 4 x 20-pin	1 x 40-pin 1 x DB-37	1 x 40-pin 1 x DB-37
Daughter board	DB-37, DN- 37, DB-8125	DB-37, DN- 37, DB-8125	DB-37, DN- 37, DB-8125	DB-37, DN- 37, DB-8125, DB-8025	DB-37, DN- 37, DB-8125	DB-37, DN- 37, DB-8125
Page	52	54	53	55	56	57



ISO-AD32H/ISO-AD32L

200K/s 12-Bit; 32-Channel Isolated Analog Input Board

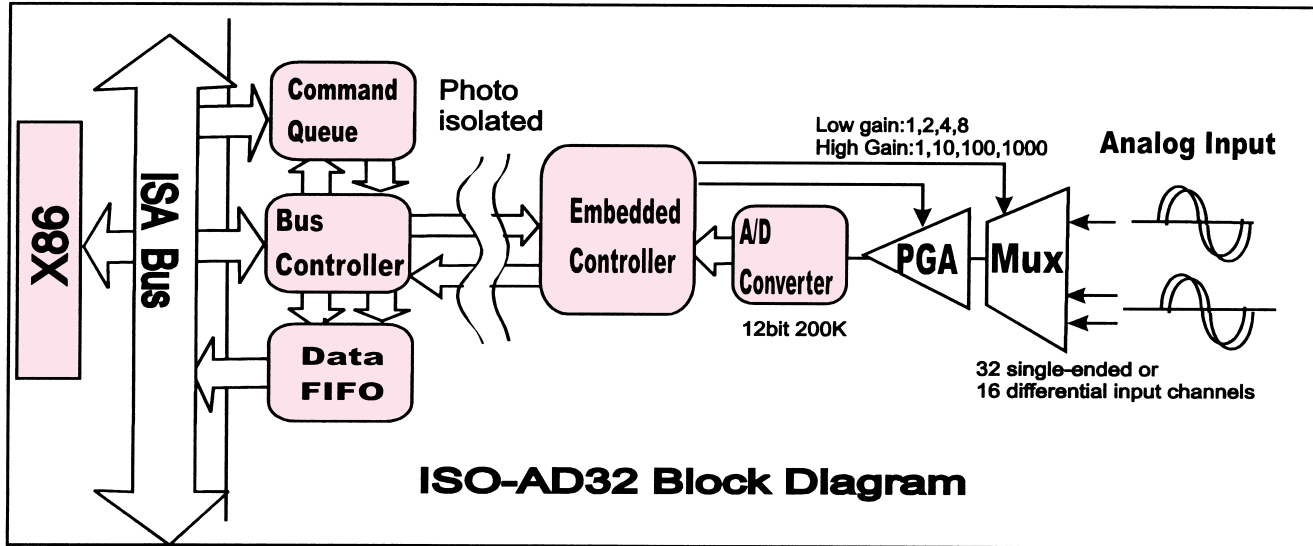

ISA-Bus

General Environment

- Operating temp: 0-50°C
- Storage temp: -20°C to 70°C
- Humidity: 0 to 90%
- Dimensions: 173 mm x 122 mm

Software

- ISO-AD32 Development Toolkit for DOS
- ISO-AD32 Development Toolkit for Win95
- ISO-AD32 Development Toolkit for WinNT

Order Description

- ISO-AD32H: 32 channel high gain isolated analog input
- ISO-AD32L : 32 channel low gain isolated analog input

Options

- DN-37: I/O connector block with DIN-rail mounting and 37-PIN D-SUB connector on it
- DB-1825: Screw Terminal Board

- ISO-AD32 LabVIEW Development Toolkit for Win95
- ISO-AD32 LabVIEW Development Toolkit for WinNT

Pin Assignments

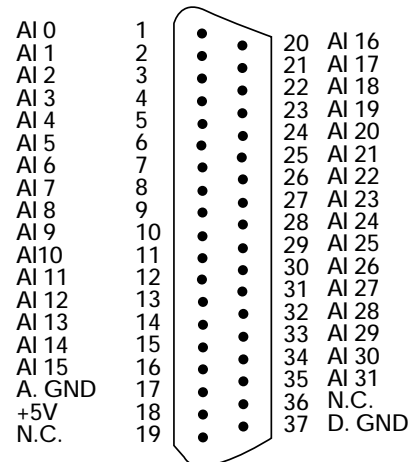

Note:

AI_n: Analog Input Channel

A. GND: Analog Ground

D. GND: Digital Ground

+5V: On Board DC to DC Converter; +5V Output

Distribué par :



2 rue René Laennec 51500 Taissy France
Fax: 03 26 85 19 08, Tel : 03 26 82 49 29

Email : hvssystem@hvssystem.com
Site web : www.hvssystem.com



ISO-DA8/ISO-DA16

14-Bit 8/16 Channel Isolated Analog Output Board

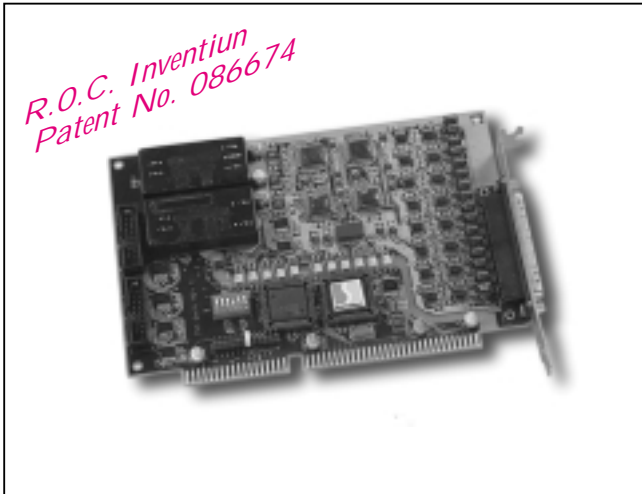

Functional Description

The ISO-DA8/16 is an Bus-type isolated 14-bit D/A card for PC/AT compatible computers. The optical isolation of the ISO-DA8/16 can operate with up to 2500Vrms of common-mode voltage.

The ISO-DA8/16 offers 8/16 channel double-buffered analog outputs. The output range may be configured in different ranges: $\pm 10V$, $\pm 5V$, 0~10V, 0~5V voltage output or 4 to 20mA / 0 to 20mA current loop sink. The innovative design improve several drawbacks of the conventional isolated D/A card. For example : 1). Jumperless, Trimless 2). The power-on value of analog output can be pre-defined by the user and stored in the on board EEPROM 3) The calibration is performed under software control, thus eliminating manual trimpot adjustments. The calibration data is stored in EEPROM. Easy recalibration ensures the accuracy of the board 4). Every channel can be selected as voltage or current output 5). High channel count output can be implemented in half size.

Features

- AT bus
- 2500VDC photo-isolation protection
- 8/16 channel, 14-bit analog output
- Unipolar or bipolar outputs available from each converter
- Voltage/Current output from each converter
- Output type (Unipolar or bipolar) and output range (0-5V,+/-5V,0-10V,+/-10V) can be software programmable

- 4-20mA current sink to ground from each converter
- Double-buffered D/A latches
- Command set programming
- Software Calibration
- 16 channel DI, 16 channel DO

Applications

- Programmable voltage source
- Programmable current sink
- Harsh environment operation
- Process control

Specifications

■ Analog Outputs

D/A converter: Quad 14-Bit MDAC
Channels: 8/16 independent
Resolution: 14 bits
Type: double-buffered, multiplying
Integral linearity: 0.006% FSR; typical
Differential linearity: 0.006 % FSR; typical

■ Voltage Output Range :

Unipolar: 0~5V or 0~10V
Bipolar: +/-10Vor,+/- 5V
Current drive: +/-5mA
Absolute accuracy: 0.01% FSR typical
Power on state: programmable

■ Current Output Range :

0-20mA or 4-20mA
Absolute Accuracy: 0.1% FSR typical
Excitation voltage range: + 7 V to +40V
Power On state: programmable

■ Digital I/O

Inputs: 16 channels/ TTL levels
Outputs: 16 channels/ TTL levels

■ Stability

Offset temperature coefficient: +/- 50 μ V/ $^{\circ}$ C
Gain temperature coefficient: +/- 10ppm/ $^{\circ}$ C



ISO-DA8/ISO-DA16

14-Bit 8/16 Channel Isolated Analog Output Board

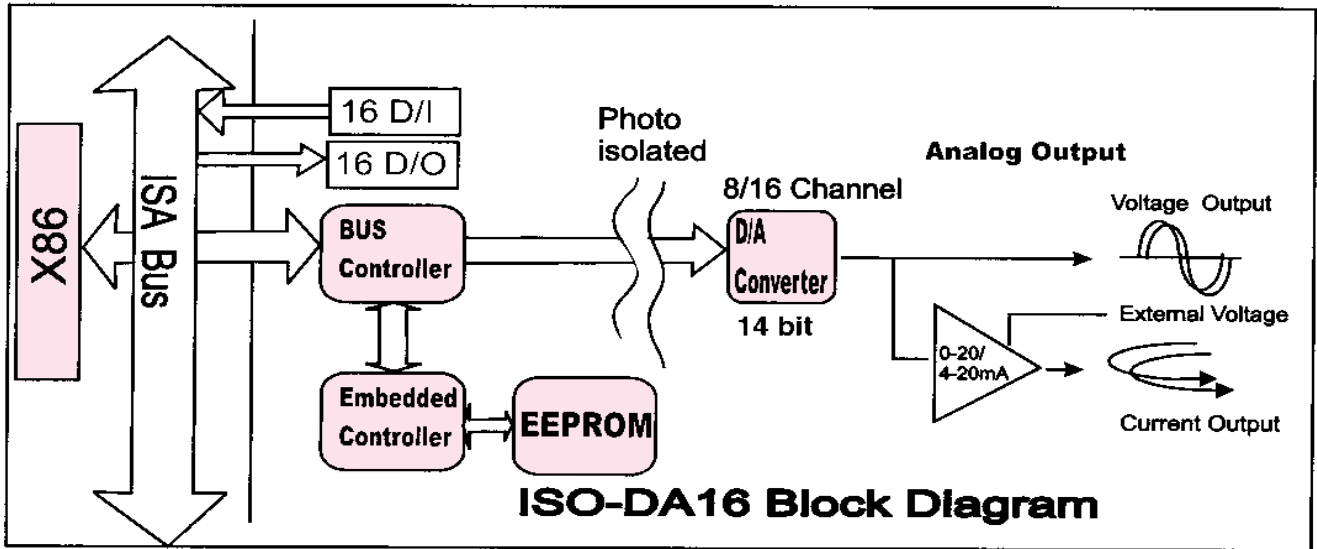

ISA-Bus

Power Requirements

- ISO-DA8: +5VDC @800mA max.
- ISO-DA16: +5VDC @1400mA max.

General Environment

- Operating temp: 0-50°C
- Storage temp: -20°C to 70°C
- Humidity: 0 to 90%
- Dimensions: 182 mm x 122 mm

Software

- ISO-DA Development Toolkit for DOS
- ISO-DA Development Toolkit for Win95
- ISO-DA Development Toolkit for WinNT

Order Description

- ISO-DA8: 8 Channel 14 BIT Isolated Analog Output Board
- ISO-DA16: 16 Channel 14 BIT Isolated Analog Output Board

Options

- DN-37: I/O connector Block with DIN- Rail mounting
- DB-37: 37-pin directly connect board
- ADP-20/PCI: 20-pin Extender
- ISO-DA LabVIEW Development Toolkit for Win95
- ISO-DA LabVIEW Development Toolkit for WinNT

Pin Assignment

V 0	1	•	20	I 0
V 1	2	•	21	I 1
V 2	3	•	22	I 2
V 3	4	•	23	I 3
AGND	5	•	24	AGND
V 4	6	•	25	I 4
V 5	7	•	26	I 5
V 6	8	•	27	I 6
V 7	9	•	28	I 7
AGND	10	•	29	AGND
V 8	11	•	30	I 8
V 9	12	•	31	I 9
V 10	13	•	32	I 10
V 11	14	•	33	I 11
AGND	15	•	34	I 12
V 12	16	•	35	I 13
V 13	17	•	36	I 14
V 14	18	•	37	I 15
V 15	19	•		

Note:

- AO_n: Analog Voltage Output Channel
- IO_n: Current Loop Output Channel
- A.GND: Analog Ground



ISO-LDH/ISO-LDL

Isolated Strain Gauge Type Loadcell Input Board

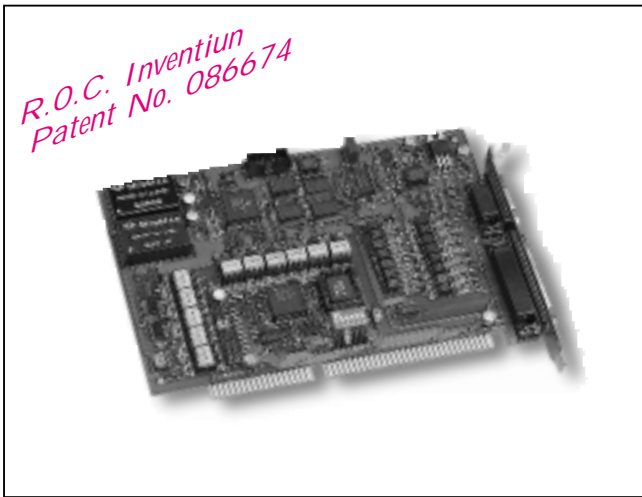

Functional Description

The ISO-LD series is a Bus-type isolated loadcell input board. The isolation inputs can operate with up to 500Vrms of common-mode voltage.

The ISO-LD series features a 12 bit analog-to-digital converters, on board 1 K bytes FIFO buffer, one loadcell signal input channel, one analog input channel, 8-channel 12-24V isolated digital inputs, 7-channel isolated open-collector digital outputs, one programmable 8-bit LED indicator to indicate the magnitude of strain gauge input signal. The ISO-LD series board is suitable for static force measurement and dynamic force analysis. Because there are on board excitation voltage, high gain amplifier, user don't have to buy any excitation voltage and signal conditioning module.

The board also have some special features, such as: 1). 12-bit programmable offset voltage. Therefore the user can cancel the DC bias and amplify the AC signal; 2). The isolated structure eliminate the ground loop noise and protect your computer; 3). On board FIFO buffer support gap-free A/D conversion under DOS environment; 4). Except the loadcell input channel, there are a lot digital I/O and one analog input channel. The user can implement a measurement and analysis system.

Features

- n AT bus
- n 500 VDC photo-isolation protection
- n one strain gauge input channel
- n One analog input channel
- n Built-in 1K bytes FIFO
- n Excitation voltage for loadcell: 12V, 50mA
- n Maximum gain up to 40,000
- n Programmable 12-bit resolution, DC offset voltage (0-5V)

- n Second order low pass filter build-in
- n Direct connection to strain gauge type loadcell
- n 8-channel 12-24V isolated digital input
- n 7-channel isolated open-collector digital output
- n Programmable 8 bits LED indicator
- n Command set programming

Applications

- n Strain gauge type loadcell measurement
- n Dynamic force on line monitoring system
- n Dynamic pressure measurement

Specifications

n Analog Input Specifications

- Channels: 1 loadcell input channel & 1 analog input channel
- Resolution: 12-bits
- Conversion rate: 16 KS/s max
- Nonlinearity: +/- 0.01 %
- Gain error: 0.005% of reading maximum
- Input Impedance: 10,000MΩ | 6pF
- bias current: +/- 3 nA (maximum)
- Input offset current: +/- 2 nA (maximum)
- CMRR: 90 dB (Minimum)
- Recommended warm-up time: 10 minutes
- On chip sample & hold

n ISO-LDH Input Range

- Analog input range: 0~10V, 0 ~1V, 0~0.1V, 0~0.01V
- Strain Gauge input range: 0 ~ 37.5mV
- Resolution

Gain	Input range(mV)
400	0~37.5
4,000	0~15
40,000	0~12.75

n ISO-LDL Input Range

- Normal input range: 0~10V, 0~5V, 0~2.5V, 0~1.25V
- Loadcell input range: 0 to 37.5mV
- Loadcell offset voltage adjustment: 0 to -5V, 8-bit
- Resolution

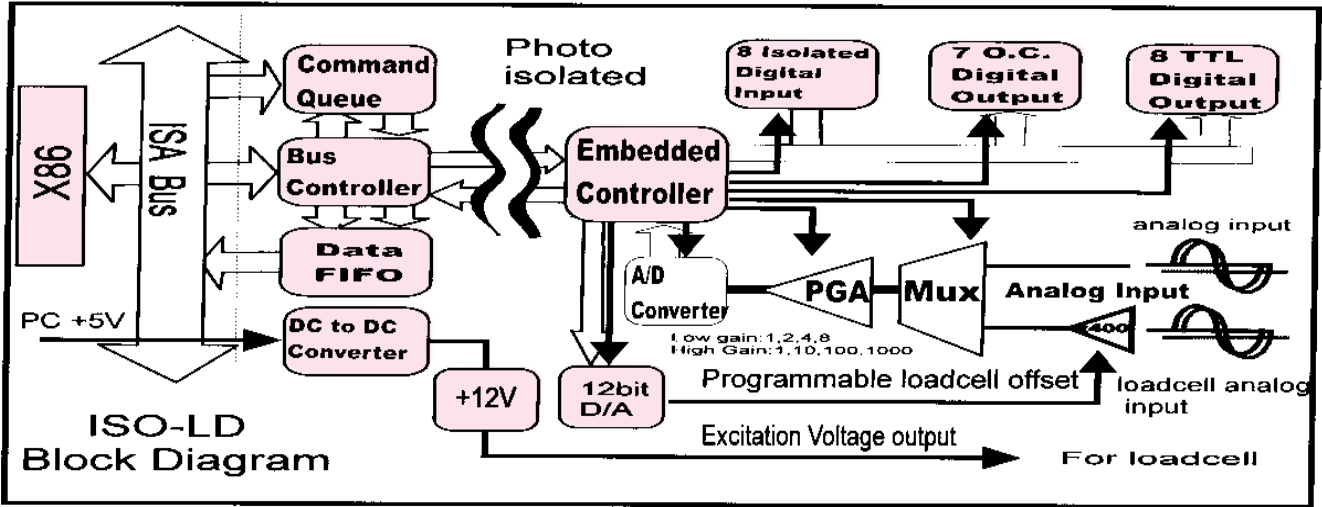

Gain	Input range(mV)
400	0~37.5
800	0~25
16,00	0~18.75
3,200	0~15.625

- **Loadcell Offset Voltage Adjustment**
0 to -5V, 12-bit resolution
- **Digital I/O**
8 photo-isolated 12~24V digital input
7 isolated open-collector digital output (100mA)
8 TTL/LED output

Software

- ISO-LD Development Toolkit for DOS

Order Description

- ISO-LDH: High gain loadcell input and digital I/O board
- ISO-LDL: Low gain loadcell input and digital I/O board

Options

- DN-25 I/O Connector block with DIN rail mounting
- S-50: S type loadcell

S TYPE LOADCELL SENSORS

There are a lot Strain Gauge type LOADCELL sensors available for the ISO-LD board. The user can find the S-50 Loadcell from options to match ISO-LD board to implement a loadcell measurement starter kit.

Specifications

- Capacity: 60Kg
- Rated Output: 2 mV/V
- Total error: 0.05%
- Repeatability: 0.03%
- Creep: 0.05%/30 min
- Resolution: 1/10,000
- Input Resistance: 410 +/- 15Ω
- Output Resistance: 350 +/- 5Ω
- Max. Excitation Voltage: 20V
- Compensated Temperature Range: -10°C ~ 50°C
- Safe Temperature Range: -20°C ~ 70°C
- Temp. Effect on Rate Output: 0.03% Load/10°C
- Zero Balance: ±5% R.O.
- Safe Overload Rating: 150%
- Cable Length: 2M
- Cable connection: Input:Red(EX+), Black(EX-)
Output: Green(LS+), White(LS-)

Free: Application notes - A002

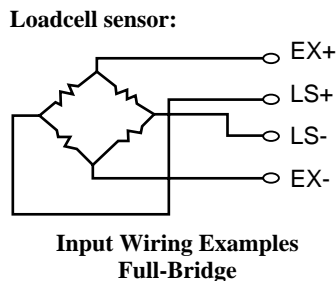
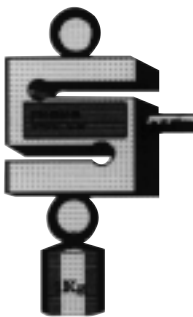

- Power Requirements: +5V @400mA(max)
- General Environment
- Operating temp: 0-50°C
- Storage temp: -20°C to 70°C
- Humidity: 0 to 90%
- Dimensions: 190 mm x 105 mm

EX+ : Excitation Voltage +
LS+ : Loadcell+
LS- : Loadcell-
EX- : Excitation Voltage-



ISO-813

32 Channel Single-ended Isolated Analog Input Board

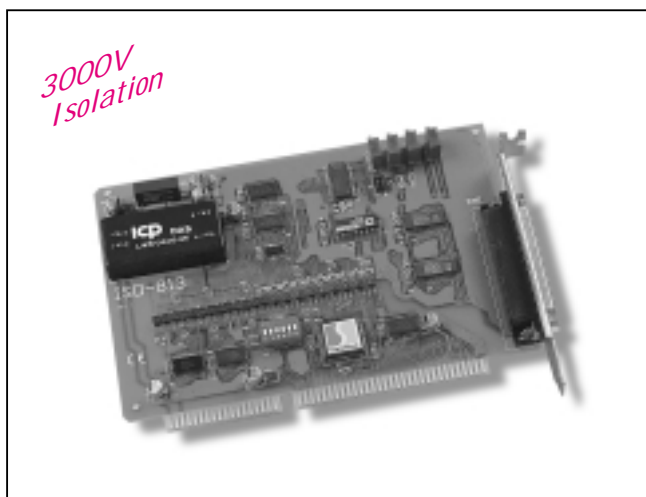

Functional Description

The ISO-813 is a bus-type isolated 12-bit A/D board for PC/AT compatible computers. Its isolation range is increased to 3000 V and extend the application field to real industry application. It is backward compatible to 813 families. Comparing to PCL-813 or ACL-8113, the ISO-813 add X 16 Programmable Gain Control range . FPGA on board can increase the stability of this board. It is the most cost effective isolated A/D board in the world. If the user need high sampling rate, differential input and FIFO onboard isolated A/D card, please refer to our ISO-AD32.

Features

- 32 single-ended analog input channels
- 12-bit A/D converter (ADS 774 or equivalent)
- 3,000Vdc photo-isolation protection
- Analog input range
 - Bipolar : +/- 5V, +/-2.5V, +/-1.25V, +/-0.625V, +/-0.3125V
 - Unipolar: 0-10V, 0-5V, 0-2.5V, 0-1.25V, 0-0.625V
- Programmable gain control
- 3000V DC/DC converter build in
- A/D trigger mode: Software Trigger
- A/D data transfer mode : polling

Applications

- Data acquisition
- Harsh environment operation
- Signal isolation

Specifications

■ Analog Input Specifications

- Channels : 32 single-ended
- Resolution : 12 bits
- Conversion rate : 10KS/s max.
- Input impedance : 10 M Ω
- Overvoltage protection : +/-35V
- Accuracy : 0.01% of reading +/- 1 bit
- Linearity : +/- 1 bit
- On chip sample & hold
- Zero drift : +/-25ppm/ $^{\circ}$ C of FS max.
- Power Requirements:** +5V @850mA max.

■ General Environmental

- Operating temp: 0-50 $^{\circ}$ C
- Storage temp: -20 $^{\circ}$ C to 70 $^{\circ}$ C
- Humidity: 0 to 90% non-condensing
- Dimensions: 174 mm x 122 mm

- NAPDOS : Library and demo program for DOS

Software

- ISO-813 Development Toolkit for DOS
- ISO-813 Development Toolkit for Win95
- ISO-813 Development Toolkit for WinNT

Order Description

- ISO-813 32 channel isolated analog input board

Options

- DB-8325: Daughter board with signal conditioning circuitry
- DB-37: Directly connect signals to the back of ISO-813
- DN-37: I/O connector block with DIN-Rail mounting and 37-PIN D-SUB connector on it
- ISO-813 LabVIEW Development Toolkit for Win95
- ISO-813 LabVIEW Development Toolkit for WinNT



ISO-P32C32

32-Channel Optically Isolated Digital Input and 32-Channel Optically Isolated Open-Collector Output

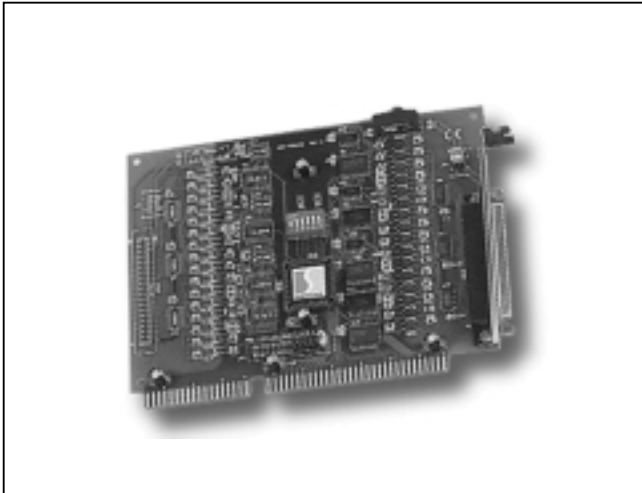

Functional Description

The ISO-P32C32 has 32 channels of optically isolated digital inputs and 32 channels of optically isolated digital outputs, arranged into four isolated banks. Each input channel use a photo-coupler input which allows either internal isolated power supply or external power selected by jumper. Each digital output offers a darlington transistor and integral suppression diode for inductive load. Isolated input channels 0-15 are designed into group A and channels 16-31 are designed into group B. Isolated output channels are designed into group C and Group D. The power supply of the input port may use the external power or the power from the PC side using DC/DC converter. The power supply of the output port should use the external power. This interface board is easily installed in any PC/AT/XT. The board interface to field logic signals, eliminating ground-loop problems and isolating the host computer from damaging voltages. The ISO-P32C32 has one 37-pin D-Sub connector and one 40-pin male header. The 40-pin to DB-37 flat-cable is used to fixed with the case. The user can connect the digital signal through the second D-Sub connector . Each D-Sub connector contains 16 input channels and 16 output channels.

Features

- 32-channel optically isolated digital input
- 32-channel optically isolated digital output /open-collector
- DC/DC converter build-in
- Four isolated bank.
- 3000V DC isolation voltage
- Interrupt level: 3,4,5,6,7,9,10,11,12,14,15
- Interrupt source : channel 0 and channel 15

Applications

- Factory Automation
- Product Test
- Laboratory Automation

Specification

Isolated Input

- Type : Isolated current input
- Isolation Voltage : 3750V(Using External Power); 3000V (Using internal Power)
- Input voltage : 3.5V to 30V
- Input impedance : 3K (DC 24V, 7.67mA) for each channel)
- Response time: 10Khz Max

Isolation Output

- Type : Isolated open-collector : 100mA per channel
- External voltage : 30V (Max.)
- Response time: 10Khz Max
- Power requirements : +5V, 600mA (typical)
- General Environmental
 - Operating temp: 0-50°C
 - Storage temp: -20°C to 70°C
 - Humidity: 0 to 90% non-condensing
 - Dimensions: 163 mm x 115 mm

Software

- ISO Development Toolkit for DOS
- ISO Development Toolkit for Win95
- ISO Development Toolkit for WinNT

Order Description

- ISO-P32C32 : 32-channel isolated Digital Input and 32 -channel isolated Open-Collector Output Board

OPTIONS

- DB-37: Directly connect signals to the back of ISO-P32C32
- DN-37: I/O Connector Block with DIN-Rail Mounting and 37-PIN D-SUB Connector
- ISO LabVIEW Development Toolkit for Win95
- ISO LabVIEW Development Toolkit for WinNT

Pin Assignment

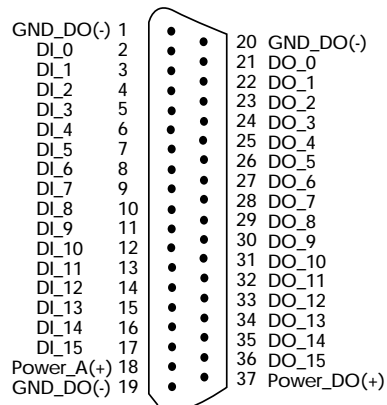



ISO-P64

64-Channel Optically Isolated Digital Input Board

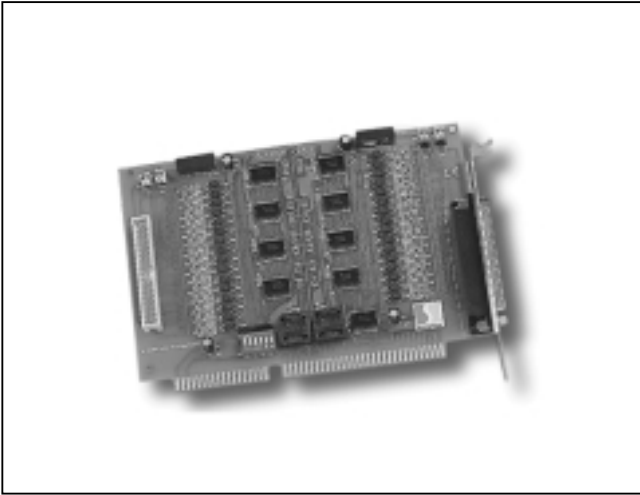

Functional Description

The ISO-P64 has 64 channels of optically isolated digital inputs, arranged into four banks. Each input channel use a photo-coupler input which allows either internal isolated power supply or external power selected by jumper. Isolated input channels 0-15 are designed into group A, channels 16-31 are designed into group B, channels 32-47 are designed into group C and channels 48-63 are designed into group D. The power supply of the input port may use the external power or the power from the PC side using DC/DC converter. The board interface to field logic signals, eliminating ground-loop problems and isolating the host computer from damaging voltages. The ISO-P64 has one 37-pin D-Sub Connector and one 40-pin male header. The 40-pin to DB-37 flat cable is used to fix with the case. The user can connect the digital signal through the second D-Sub connector. Each D-Sub connector contains 32 input channels.

Features

- 64-channel optically isolated digital input
- DC/DC converter build-in
- Four isolated bank
- 3000V DC isolation voltage

Applications

- Factory Automation
- Product Test
- Laboratory Automation

Specifications

Isolation Input

Type : Isolated current input

- Isolation Voltage : 3750V(Using External Power); 3000V (Using internal Power)
- Input voltage : 3.5V to 30V
- Input impedance : 3K (DC 24V, 7.67mA) for each channel)
- Response time: 1Khz Max
- Power requirements : +5V 400mA (typical)

General Environmental

Operating temp: 0-50°C

Storage temp: -20°C to 70°C

Humidity: 0 to 90% non-condensing

Dimensions: 163 mm x 115 mm

Software

- ISO Development Toolkit for DOS
- ISO Development Toolkit for Win95
- ISO Development Toolkit for WinNT

Order Description

- ISO-P64: 64 channel isolated Digital Input Board

OPTIONS

- DB-37: Directly connect signals to the back of ISO-P64
- DN-37: I/O Connector Block with DIN Rail Mounting and 37-PIN D-SUB Connector
- ISO LabVIEW Development Toolkit for Win95
- ISO LabVIEW Development Toolkit for WinNT

Pin Assignment

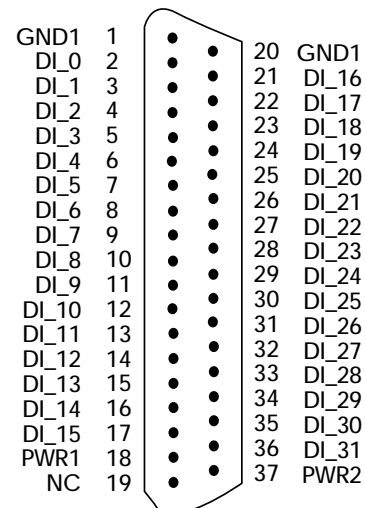



ISO-C64

64-Channel Optically Isolated Open-Collector Digital Output Board

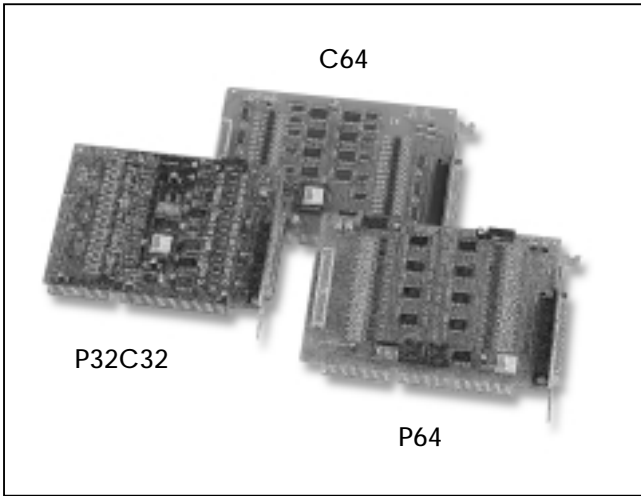

ISA-Bus

Functional Description

The ISO-C64 has 64 channels of optically isolated digital outputs, arranged into four isolated banks. Each digital output offers a darlington transistor and integral suppression diode for inductive load. Isolated output channels are designed into group A,B,C,D. The power supply of the output port should use the external power. This interface board is easily installed in any PC/AT/XT. The board interface to field logic signals, eliminating ground-loop problems and isolating the host computer from damaging voltages. The ISO-C64 has one 37-pin D-Sub Connector and one 40-pin male header. The 40-pin to DB-37 flat cable is used to fixed with the case. The user can connect the digital signal through the second D-Sub connector . Each D-Sub connector contains 32 output channels.

Features

- 64-channel optically isolated digital output /open collector
- Four isolated bank.
- 3750V DC isolation voltage

Applications

- Factory Automation
- Product Test
- Laboratory Automation

Specifications

Isolation Output

- Type : Isolated open collector : 100mA per channel
- External voltage : 30V (Max.)
- Response time: 1Khz Typical
- Power requirements : +5V 800mA (typical)

General Environmental

- Operating temp: 0-50°C
- Storage temp: -20°C to 70°C
- Humidity: 0 to 90% non-condensing
- Dimensions: 163 mm x 115 mm

Software

- ISO Development Toolkit for DOS
- ISO Development Toolkit for Win95
- ISO Development Toolkit for WinNT

Order Description

- ISO-C64 : 64 -channel isolated Digital Output Board

OPTIONS

- DB-37: Directly connect signals to the back of ISO-C64
- DN-37: I/O Connector Block with DIN Rail Mounting and 37-PIN D-SUB Connector
- ISO LabVIEW Development Toolkit for Win95
- ISO LabVIEW Development Toolkit for WinNT

Pin Assignment

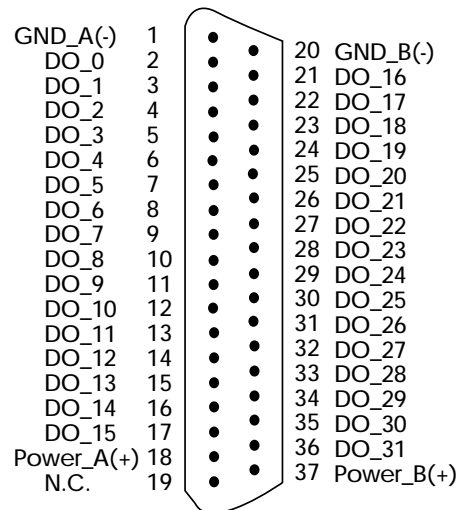



ISO-730

32 Channel Isolated Digital I/O Board

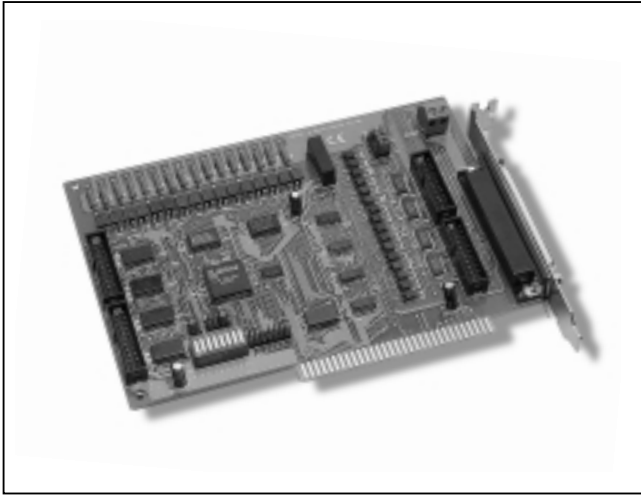

Functional Description

The ISO-730 has 32 Isolated digital I/O channels (16 DI and 16 DO) and 32 TTL digital I/O channels. Each of the 16 isolated digital input channel accept voltage from 5V to 24V and has a resistance of 1.2K Ω . Every eight input channels use one external common ground. For example, channel 0-7 use EI-COM1 and channel 8-15 use EI-COM2. Each of the 16 isolated digital output channels equipped a darlington transistor. Every eight output channels use the common emitters. The power supply of the output port should use the external power. The channels 0-7 use EO-COM1 and channels 8-15 use EO-COM2. This interface board is easily installed in any PC/AT/XT. The board interface to field logic signals, eliminating ground-loop problems and isolating the host computer from damaging voltages.

The ISO-730 has one 37-pin D-Sub Connector and four on-board 20-pin flat-cable connectors. It is fully compatible to PCL-730.

Features

- 32 isolated DIO channels
- 32 TTL-level DIO channels (Non-isolated)
- DC/DC converter build-in
- Two separate 20-pin connectors for isolated input and output channels.
- Two separate 20-pin connectors for non-isolated input and output channels.
- 2500Vdc isolation voltage
- Interrupt level: 2,3,4,5,6,7

Applications

- Factory Automation
- Product Test
- Laboratory Automation

Specifications

Digital Input

16 Optical-isolated inputs

- Type : Isolated current input
- Isolation Voltage : 2500Vdc
- Input voltage : 5V to 24Vdc
- Input impedance : 1.2K Ω , 0.5W
- Response time: 10Khz Max.

16 TTL-level inputs

- Input voltage: High : 2.0V min.
Low: 0.8V max.
- Input load: High: 0.05mA max. @2.7V
Low: 0.4mA max. @0.5V
- Response time :30KHz typical

Digital Output

16 optical-isolated outputs

- Output voltage: open collector 5 to 40Vdc
- Isolation voltage : 2,500Vdc
- Sink current: 200mA max.
- Response time : 10KHz max.

16 TTL-level Outputs

- Output voltage:
High : Source 0.4mA at 2.4V min.
Low: Sink 8 mA at 0.5V max.
- Interrupt Source:
Channel 0 and 1 of Isolated DI port or channel 0 and 1 of TTL DI port

General Environmental

- Operating temp: 0-50°C
- Storage temp: -20°C to 70°C
- Humidity: 0 to 90% non-condensing
- Dimensions: 172 mm x 124 mm

Software

- ISO Development Toolkit for DOS
- ISO Development Toolkit for Win95
- ISO Development Toolkit for WinNT

Order Description

- ISO-730 : 32-channel isolated Digital I/O board

Options

- DB-37 Directly connect signals to the back of ISO-730
- DN-37 I/O Connector Block with DIN Rail Mounting and 37-PIN D-SUB Connector
- ADP-20: 20-pin Extender
- ISO LabVIEW Development Toolkit for Win95
- ISO LabVIEW Development Toolkit for WinNT



P8R8DIO

Isolated 8 Digital Input & 8 Relay Output Board

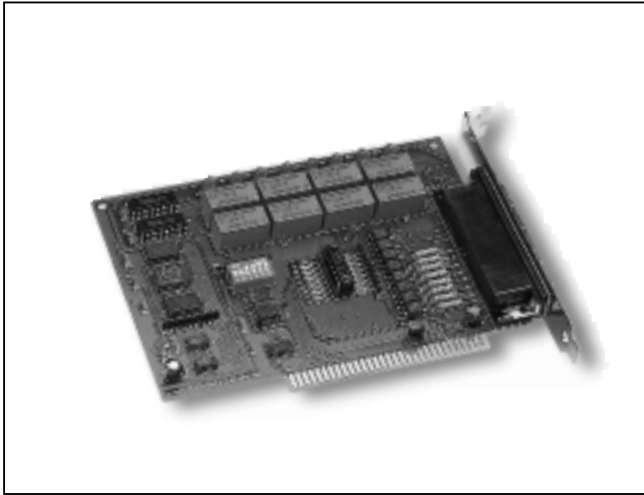

Functional Description

The P8R8 DIO is an 8 Isolated input and 8 relay output interface board designed for control and sensing applications. This board is easily installed in any PC/AT/XT or compatible computer. The P8R8 DIO Provides 8 electromechanical relay outputs and 8 optically isolated inputs. The P8R8 DIO can be used in various applications including load switching, external switching, contact closure, and others.

Features

- 8 Relay output Channel
- 8 optically isolated digital input channels
- DC signal Input with filter or without filter.
- AC signal input with filter
- Power Requirements: +5V @120mA(max.); +12V @ 180 mA (max.)

Applications

- Factory Automation
- Product Test
- Laboratory Automation
- Security Control

Specifications

- Relays
 - Relay output Channels: 8
 - Contact Rating: 0.3 A; 120V AC/DC / 1A; 30V DC
 - Contact arrangement: Output channel 0-3 are Form C

Output channel 4-7 are Form A
 Operating time: 5 m Sec
 Release time: 10m Sec
 Expected life > 100, 000 times (at 30V/1 A)

Inputs

Channels: 8
 Type: Non-polarized opto-isolated, (PC-814)
 Input Voltage: AC/DC 5-24V or VAC (50 -1 K Hz)
 Input Impedance: 1.2 K Ω
 Response Time: 20 μ S (without filter)
 2.2 mS (with filter)
 Isolation: 500 V channel-channel & channel-ground

General Environment

Operating temp: 0-50°C
 Storage temp: -20°C to 70°C
 Humidity: 0 to 90%
 Dimensions: 145 mm x 105 mm

Software

- DIO Development Toolkit for DOS
- DIO Development Toolkit for Win95
- DIO Development Toolkit for WinNT

Order Description

- P8R8DIO: Isolated 8 Digital Input/8 Relay Output Board

Options

- DB-37: Directly connect to the back of P8R8DIO
- DN-37: I/O Connector Block with DIN Rail Mounting and 37-PIN D-SUB Connector
- DIO LabVIEW Development Toolkit for Win95
- DIO LabVIEW Development Toolkit for WinNT

Pin Assignment

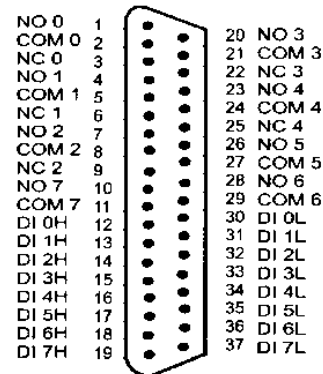

Note:

NO: Normal Open DI nH: Digital Input High
 NC: Normal Close DI nL: Digital Input Low
 Com: Common



P16R16DIO

Isolated 16 Digital Input & 16 Relay Output Board

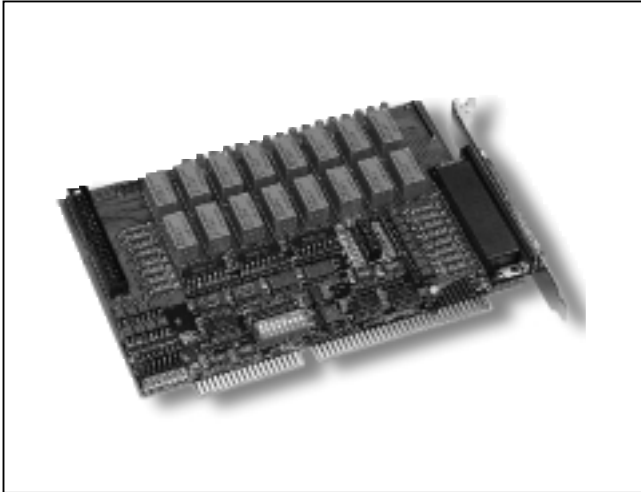

Functional Description

The P16R16 DIO is a 16 isolated digital input and 16 relay output interface board designed for control and sensing applications. This interface board is easily installed in any PC/AT/XT or compatible computer. The P16R16 DIO Provides 16 electromechanical relay outputs and 16 optically isolated inputs. The P16R16 DIO has two 37-pin D-Sub Connectors and the function is equal to two P8R8DIO.

Features

- Relay output Channel
- Optically isolated digital input channels
- AC/DC signal Input; AC signal input with filter
- Power Requirements: +5V/200mA(max.); +12V/260 mA (max.)

Applications

- Factory Automation
- Product Test
- Laboratory Automation
- Security Control

Specifications

- Relays
 - Relay output Channels:16
 - Contact Rating: 0.3 A;120V AC/DC /1A; 30V DC
 - Contact arrangement: Output channel 0-3, 8-11 are Form C; Output channel 4-7, /12-15 are Form A

Operating time : 5m Sec
Release time : 10m Sec
Expected life > 100,000 times (at 30V/1A)

■ Inputs

Channels: 16
Type: Non-polarized OPTO-isolated , (PC-814)
Input Voltage: AC/DC 5-24V or VAC Freq:50~1Khz
Input Impedance: 1.2 K Ω
Response Time: 20 μ S (without filter)
2.2mS (with filter)
Isolation: 500V channel-channel & channel-ground

■ General Environment

Operating temp: 0 - 50°C
Storage temp: -20°C to 70°C
Humidity: 0 to 90%
Dimensions: 175 mm x 121 mm

Software

- DIO Development Toolkit for DOS
- DIO Development Toolkit for Win95
- DIO Development Toolkit for WinNT

Order Description

- P16R16DIO: Isolated 16 Digital Input/16 Relay Output Board

Options

- DB-37: Directly connect signals to the back of P16R16DIO
- DN-37: I/O Connector Block with DIN Rail Mounting and 37-PIN D-SUB Connector
- DIO LabVIEW Development Toolkit for Win95
- DIO LabVIEW Development Toolkit for WinNT

The pin Assignment of P16R16DIO is the same as P8R8DIO